

Micrometer Stands

SERIES 156

These stands are designed to allow bench-top use with hand micrometers or other gages which have frame area sufficient to grab onto.

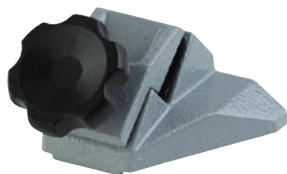

156-105



156-101



156-102

SPECIFICATIONS

Micrometer ranges	Order No.	Remarks
0-25mm (0-1"), 25-50mm (1"-2")	156-105	Fixed angle type
Up to 100mm (4")	156-101	Adjustable angle type
125-300mm (5"-12")	156-102	Vertical type
300-1000mm (12"-40")	156-103	Vertical type

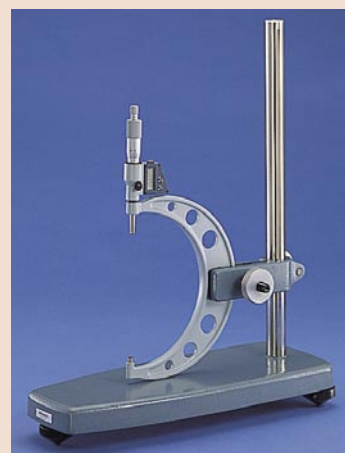

DIMENSION

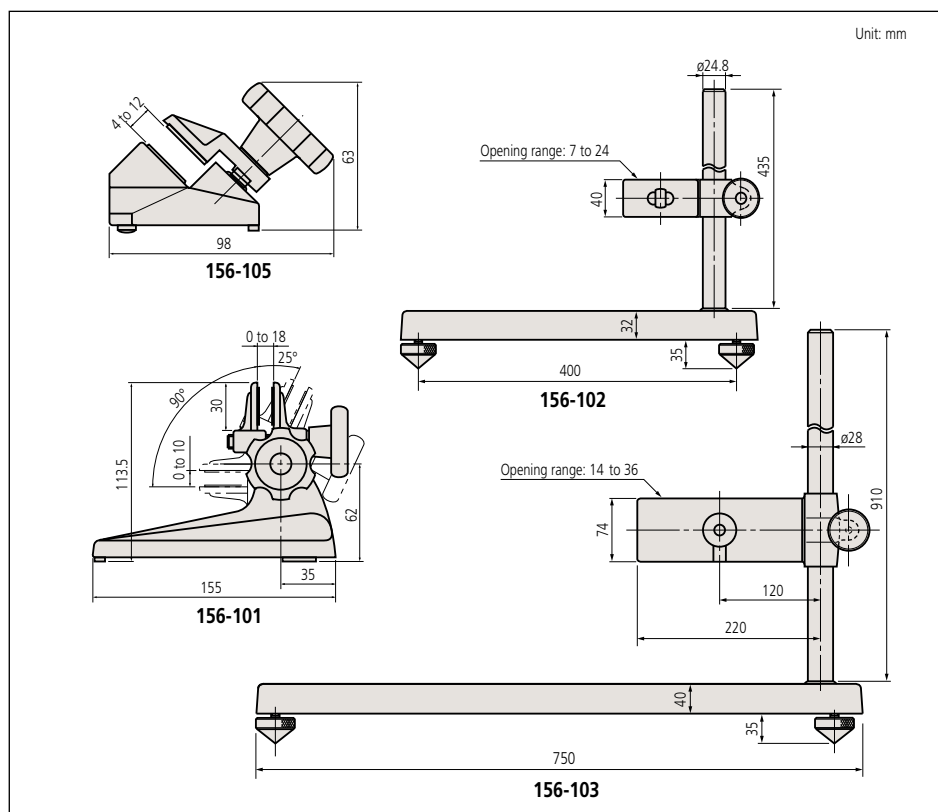

Micrometer Standards

SERIES 167

FEATURES

- Used for the zero point setting of outside micrometers.
- Flat and lapped measuring faces.
- Heat insulating handle for preventing expansion due to body temperature.



DIMENSION

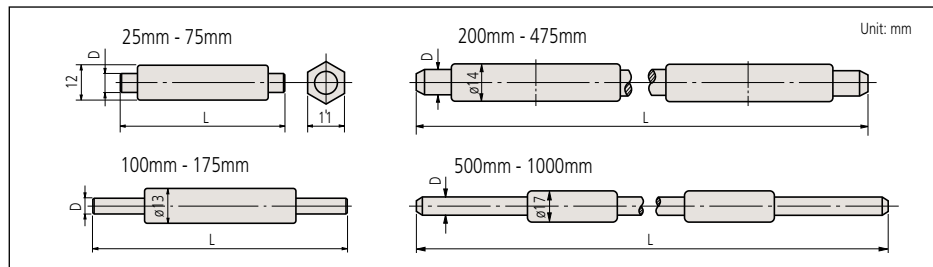

SPECIFICATIONS

Metric			
Length (L)	Order No.	Diameter (D)	Tolerance
25mm	167-101	6.35mm	±1.5µm
50mm	167-102	6.35mm	±2.0µm
75mm	167-103	6.35mm	±2.5µm
100mm	167-104	7.9mm	±3µm
125mm	167-105	7.9mm	±3.5µm
150mm	167-106	7.9mm	±4µm
175mm	167-107	7.9mm	±4.5µm
200mm	167-108	9.4mm	±5.0µm
225mm	167-109	9.4mm	±5.5µm
250mm	167-110	9.4mm	±6.0µm
275mm	167-111	9.4mm	±6.5µm
300mm	167-112	9.4mm	±7µm
325mm	167-113	9.4mm	±7.5µm
350mm	167-114	9.4mm	±8µm
375mm	167-115	9.4mm	±8.5µm
400mm	167-116	9.4mm	±9µm
425mm	167-117	9.4mm	±9.5µm
450mm	167-118	9.4mm	±1.0µm
475mm	167-119	9.4mm	±10.5µm
500mm	167-120	11.9mm	±11µm
525mm	167-121	11.9mm	±11.5µm
550mm	167-122	11.9mm	±12µm
575mm	167-123	11.9mm	±12.5µm
600mm	167-124	11.9mm	±13µm
625mm	167-125	11.9mm	±13.5µm
650mm	167-126	11.9mm	±14µm
675mm	167-127	11.9mm	±14.5µm
700mm	167-128	11.9mm	±15µm
725mm	167-129	11.9mm	±15.5µm
750mm	167-130	11.9mm	±16µm
775mm	167-131	11.9mm	±16.5µm
800mm	167-132	11.9mm	±17µm
825mm	167-133	11.9mm	±17.5µm
850mm	167-134	11.9mm	±18µm
875mm	167-135	11.9mm	±18.5µm
900mm	167-136	11.9mm	±19µm
925mm	167-137	11.9mm	±19.5µm
950mm	167-138	11.9mm	±20µm
975mm	167-139	11.9mm	±20.5µm
1000mm	167-140	11.9mm	±21µm

Available up to 2000mm.

Inch			
Length (L)	Order No.	Diameter (D)	Tolerance
1"	167-141	.25"	±1.5µm
2"	167-142	.25"	±2.0µm
3"	167-143	.25"	±2.5µm
4"	167-144	.31"	±3µm
5"	167-145	.31"	±3.5µm
6"	167-146	.31"	±4µm
7"	167-147	.31"	±4.5µm
8"	167-148	.37"	±5.0µm
9"	167-149	.37"	±5.5µm
10"	167-150	.37"	±6.0µm
11"	167-151	.37"	±6.5µm
12"	167-152	.37"	±7µm
13"	167-153	.37"	±7.5µm
14"	167-154	.37"	±8µm
15"	167-155	.37"	±8.5µm
16"	167-156	.37"	±9µm
17"	167-157	.37"	±9.5µm
18"	167-158	.37"	±1.0µm
19"	167-159	.37"	±10.5µm
20"	167-160	.47"	±11µm
21"	167-161	.47"	±11.5µm
22"	167-162	.47"	±12µm
23"	167-163	.47"	±12.5µm
24"	167-164	.47"	±13µm
25"	167-165	.47"	±13.5µm
26"	167-166	.47"	±14µm
27"	167-167	.47"	±14.5µm
28"	167-168	.47"	±15µm
29"	167-169	.47"	±15.5µm
30"	167-170	.47"	±16µm
31"	167-171	.47"	±16.5µm
32"	167-172	.47"	±17µm
33"	167-173	.47"	±17.5µm
34"	167-174	.47"	±18µm
35"	167-175	.47"	±18.5µm
36"	167-176	.47"	±19µm
37"	167-177	.47"	±19.5µm
38"	167-178	.47"	±20µm
39"	167-179	.47"	±20.5µm
40"	167-180	.47"	±21µm

Available up to 79".

Technical Data

Tolerance*: Refer to the list of specifications.
 *Tolerance on deviation of measured central length from nominal at 20°C
 Flatness: 0.3µm
 Parallelism: 2µm



Standards for Screw Thread Micrometers

SERIES 167 — 60 degree and 55 degree

FEATURES

- Specially designed for the zero point setting of screw thread micrometers.



Technical Data

Accuracy: Refer to the list of specifications.
Thread angle: 55° or 60°

SPECIFICATIONS

Metric			
Length	Order No.	Thread angle	Accuracy
25mm	167-261	60°	±4μm
	167-272	55°	±4μm
50mm	167-262	60°	±5μm
	167-273	55°	±5μm
75mm	167-263	60°	±6μm
	167-274	55°	±6μm
100mm	167-264	60°	±7μm
	167-275	55°	±7μm

Inch			
Length	Order No.	Thread angle	Accuracy
1"	167-294	60°	±4μm
	167-283	55°	±4μm
2"	167-295	60°	±5μm
	167-284	55°	±5μm
3"	167-296	60°	±6μm
	167-285	55°	±6μm
4"	167-297	60°	±7μm
	167-286	55°	±7μm

Standards for V-Anvil Micrometers

SERIES 167

FEATURES

- Specially designed for the zero point setting of V-anvil micrometers.

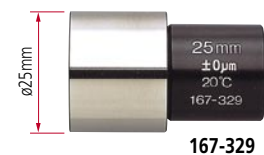

Technical Data

Accuracy: Refer to the list of specifications.

SPECIFICATIONS

Metric			
Length	Order No.	Type	Accuracy
5mm	167-327	Plug	±2μm
10mm	167-328	Plug	±2μm
25mm	167-329	Plug	±2μm
40mm	167-330	Ring	±3μm
55mm	167-331	Ring	±3μm
70mm	167-332	Ring	±3μm
85mm	167-333	Ring	±3μm

Inch			
Length	Order No.	Type	Accuracy
.2"	167-337	Plug	±2μm
.4"	167-338	Plug	±2μm
1"	167-339	Plug	±2μm
1.6"	167-340	Ring	±3μm
2.2"	167-341	Ring	±3μm
2.8"	167-342	Ring	±3μm
3.4"	167-343	Ring	±3μm