

Surftest SV-2000/3000

Bulletin No. 1713



Surface Roughness Measuring System
Powerful and easy to use

Mitutoyo

Surface Roughness Testing System
Surface Roughness Testing System

Surftest SV-2000/3000

- Mitutoyo's Surftest SV-2000/3000 Series provides high accuracy, high-level analysis and multi-functionality in 3D surface roughness analysis and finely detailed contour measurements, as well as conventional 2D surface roughness measurements.
- Optional accessories, such as the auto-leveling table and three-axis adjustment table, are available to enhance operability and to enable automatic measurement.
- SURFPAK®, a dedicated data-analysis software package, is installed as standard equipment. This gives data management a consistent format from the work site to the laboratory.
- TCON, the easy-to-use Touch-Panel Controller, makes high-level analysis affordable.



Easy-to-use Surface Roughness and Contour Evaluation Software!

- Various data analyzing programs are available to satisfy a wide range of measuring needs: SURFPAK®-SV evaluates workpiece surface roughness two-dimensionally, while SURFPAK®-PRO does the same in three dimensions. FORMPAK®-SV evaluates surface contours.
- An ample selection of internationally recognized surface roughness parameters is provided.
- From a simple measurement to high-level data analysis, operations can be performed easily and speedily just by pointing and clicking.

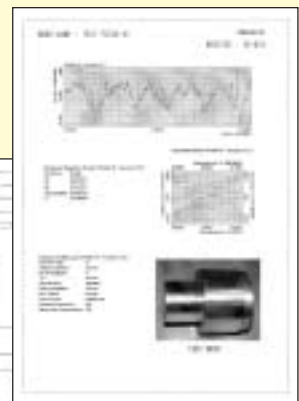
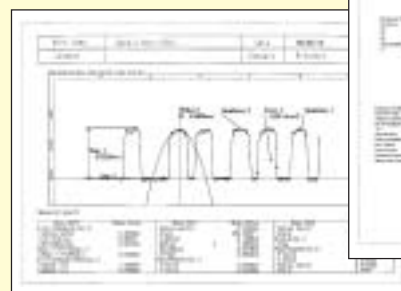
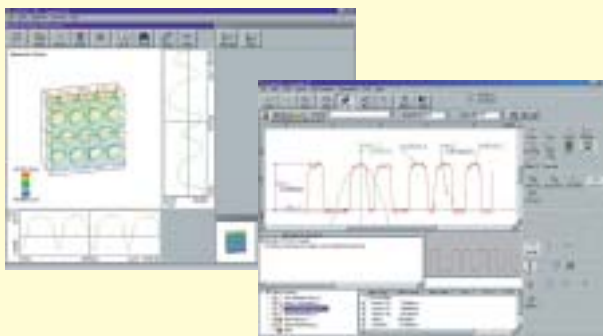

Convenient Report-Generation Function

- Surface roughness evaluation results can be output to a printer as an Evaluation Report.

SV-3000M4

Traverse range:
100mm (4")
Vertical travel:
300mm (11.8")
Base size (WxD):
610x450mm
(24"x17.7")

SV-2000S2

Traverse range:
50mm (2")
Vertical travel:
300mm (11.8")
Base size (WxD):
610x450mm
(24"x17.7")

SV-2000N2

Traverse range:
50mm (2")
Vertical travel:
—
Base size (WxD):
—

SV-3000S4

Traverse range:
100mm (4")
Vertical travel:
300mm (11.8")
Base size (WxD):
610x450mm
(24"x17.7")

SV-3000H4

Traverse range:
100mm (4")
Vertical travel:
500mm (19.7")
Base size (WxD):
610x450mm
(24"x17.7")

SV-3000W8

Traverse range:
200mm (8")
Vertical travel:
500mm (19.7")
Base size (WxD):
1010x450mm
(40"x17.7")

SV-3000W4

Traverse range:
100mm (4")
Vertical travel:
500mm (19.7")
Base size (WxD):
1010x450mm
(40"x17.7")

SV-3000S8

Traverse range:
200mm (8")
Vertical travel:
300mm (11.8")
Base size (WxD):
610x450mm
(24"x17.7")

SV-3000H8

Traverse range:
200mm (8")
Vertical travel:
500mm (19.7")
Base size (WxD):
610x450mm
(24"x17.7")

Choose from
a Variety of Models!

Select the model that best fits your needs — different base size, portable type, etc. Mitutoyo offers a full line of SV-2000/3000 Series surface measuring machines to choose from in accordance with the size of workpiece and evaluation method. Various optional accessories are also available.

2D



Non-contact sensor unit can be attached to SV-3000 series (except SV-3000M4)

Order No. **178-067**
178-067C
178-067A
178-067D

Photo: **SV-300S4**
with personal
computer system



SV-3000S4
SV-3000H4
SV-3000W4



Photo: **SV-2000N2**
with TCON

SV-2000N2

High Accuracy Mechanical Design

- Ceramic, well known for its superb anti-abrasive properties, is used as the X-axis drive unit guide. No lubrication of the guide is required.
- High-accuracy glass scales (X-axis resolution: $0.05\mu\text{m}$, Y-axis resolution: $1\mu\text{m}$) are built-in to the X- and Y-axes to insure high-accuracy positioning. The SV-3000 series demonstrate high-reliability, especially in the horizontal roughness parameters (S , S_m), that require highly accurate X-axis movement.
- Equipped with high-accuracy detector stylus.
- Equipped with several advanced functions: such as the 'straightness compensation' function, which improves the linear accuracy of the X-axis; the 'circular compensation' function for the vertical movement of the stylus; and the 'stylus-tip diameter compensation' function.
- The stylus and the skid can be replaced easily. Optional styli and skids are available for a wide variety of roughness measurement applications, such as measurement of small holes, deep holes, etc.
- An easy-to-operate Control Box is provided for the SV-2000S2, SV-3000S4/H4/W4/S8/H8/W8. The Control Box, independently of the main unit, allows positioning, measurement start/stop, retracting, and other operations to be performed remotely. The Drive Unit up/down position and the X-axis traverse can be fine-controlled manually.

Photo: **SV-3000M4**
with personal
computer system



SV-3000M4

Photo: **SV-2000S2**
with TCON



SV-2000S2



Surface roughness-analyzing program **SURFPAK®-SV**

- **Enhanced with various control functions to support automatic measurement.**
- **Equipped with a variety of evaluation parameters conforming to most of the world standards and analysis functions.**
- **Allows the operator to perform a complicated measurement easily and speedily just by pointing and clicking.**

Assessed profile window:
The size of the assessed profile display can be freely changed.

Measurement result window:
Provides a great variety of parameters conforming to most of the international standards.

Measuring condition setting window

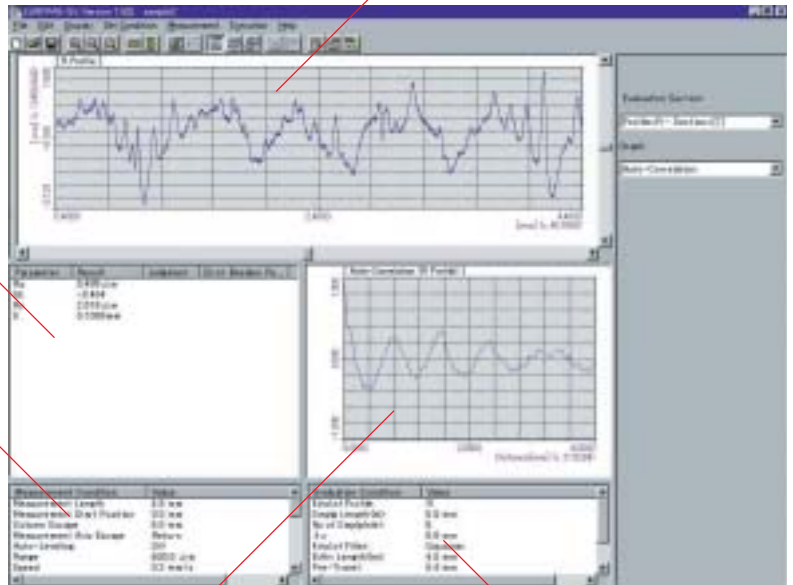

Analysis graph window:
Various analysis graphs can be created.

Evaluation conditions window:
For various recalculations of the measured data.

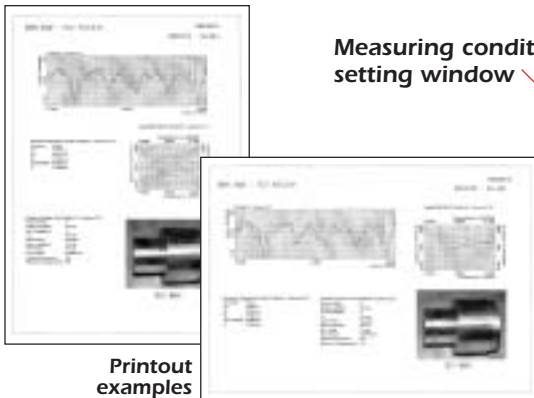

Report Generation Function

- The assessed profiles, calculation results, measuring conditions and comments can be freely formatted and printed out as reports.
- Cut and paste can be used not only on measurement data but also on image files (bit-map) to create unique reports with photos and company logos.
- Create one layout and use it repeatedly for other measurements.
- Reports can be printed on large-size paper or in color using the optional color printer.

SURFPAK® Series

- All the SURFPAK® Series surface roughness-analyzing programs have high operability and can exchange data with each other. SURFPAK®-SJ is the software for the portable model, SURFPAK®-SV is for use in the inspection room and SURFPAK®-PRO is designed for three-dimensional surface measuring machines. (Control method for the machine differs, depending on the model.)
- SURFPAK® Series software makes it easier to manage data from the manufacturing site to the laboratory because the same format can be used in surface roughness measurement as for storing and analyzing the measured data.
- Optionally, the FORMPAK®-SV program is available to evaluate surface contour.
- OS requirements:
Windows®95/Windows®98/Windows®NT4.0

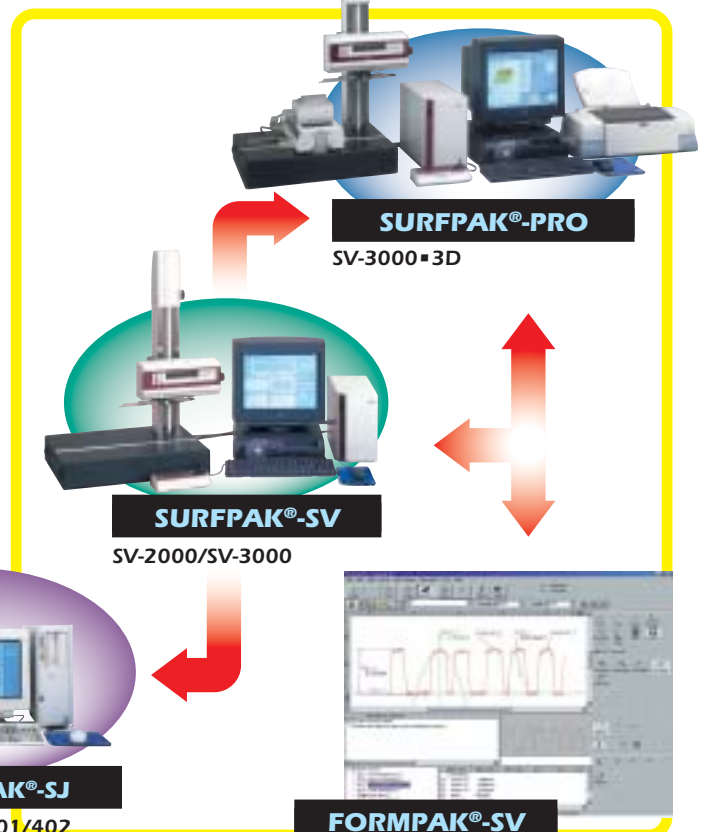



Touch-Panel Controller TCON

- Easy & speedy operation with touch-panel control
- 12-inch color LCD
- Large sized and easy-to-understand icons allow high-level analysis as well as SURFPAK-SV functionality.

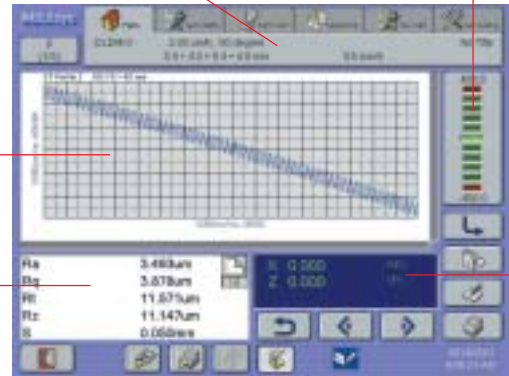

Measuring condition window

Z-axis indicator (stylus position)

Assessed profile window

Measurement result window

X and Y-axis counter

Main window

Ra	3.483um	X	0.000
Rq	3.678um	Z	0.000
Rt	11.875um		
Rz	11.147um		
S	0.080mm		



Measuring condition setting window

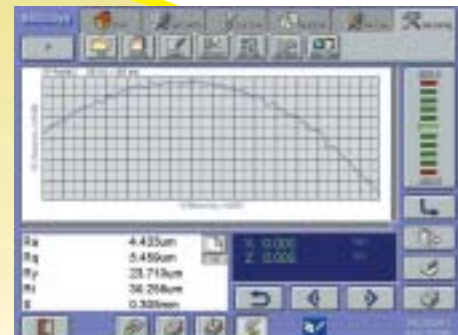

Configuration setting window

Ra	4.433um	X	0.000
Rq	5.450um	Z	0.000
Rt	23.718um		
Rz	36.208um		
S	0.320mm		



Calibration and control window





Applied analysis window

Ra	5.483um	X	0.000
Rq	5.876um	Z	0.000
Rt	11.875um		
Rz	11.147um		
S	0.080mm		

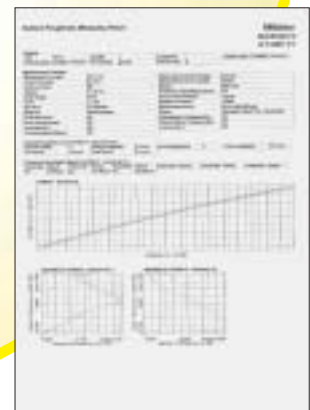

Recalculation window



Printout

Three-dimensional Surface Data Analysis



Non-contact sensor unit can be attached to SV-3000-3D
 Order No. **178-067**
178-067C
178-067A
178-067D



Note: The personal computer system and printer are optional.

SV-3000-3D

3-D Auto-leveling Table (equipped as standard)

- A multi-functional system provided with SURFPAK®-PRO, the software that measures, analyzes, and evaluates the roughness of workpiece surfaces three-dimensionally.
- From various graphics and three-dimensional surface roughness parameter analyses to volume and area measurements, a variety of surface contour evaluations can be performed freely. Selected topographic profiles can also be evaluated two-dimensionally.
- The three-dimensional auto-leveling table greatly reduces the workpiece set-up time.



SURFPAK®-PRO 3-D Analysis Functions

Three-dimensional evaluation parameters	Sa, Sq, Ssk, Sku, SΔq, SΔλ, Sz, So, Sr, Sp, Sv, St, S3y, Spc, Svc, Spd, Svd, etc.
Filter functions	Moving average filter, Gaussian filter
Three-dimensional trend compensation	Plane compensation, sphere compensation, cylinder compensation, polyhedron compensation
Three-dimensional analysis functions	3-D topography display, topographic profile analysis, BAC, ADC analysis, spectrum analysis, probability distribution analysis, local peak distribution analysis, parameter distribution analysis, slope enhancement
Topographic profile sampling function	A desired cross-section can be analyzed two-dimensionally.

The 3-D auto-leveling table, which adjusts the level of the measured surface of the workpiece automatically, is a standard accessory. This relieves the operator from the time-consuming manual adjustment that a conventional machine would require, thus greatly improving work efficiency.

Y-axis range	100mm (4")
Y-axis traverse linearity	0.2μm/100mm (8μinch/4")
Traverse speed	5mm/s (.2"/s) max.
Resolution	0.001mm (.00004")
Feeding accuracy	±(2+2L/100)μm, L= Traversing length (mm)
Leveling range	±2° (for each direction)
Max. workpiece weight	10kg (22 lbs.)



Surface roughness-analyzing program **SURFPAK®-PRO**

- SURFPAK®-PRO provides a variety of graphics methods and evaluation parameters for various surface roughness evaluations from the three-dimensional topography data.
- A topographic profile can be analyzed two-dimensionally, thus allowing evaluation of contours, in fine detail, and surface roughness at the same

Measurement result windows

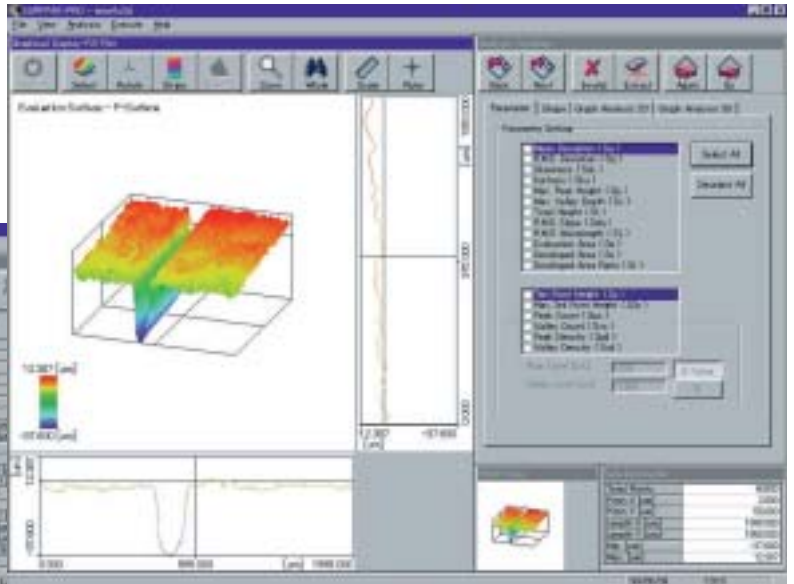
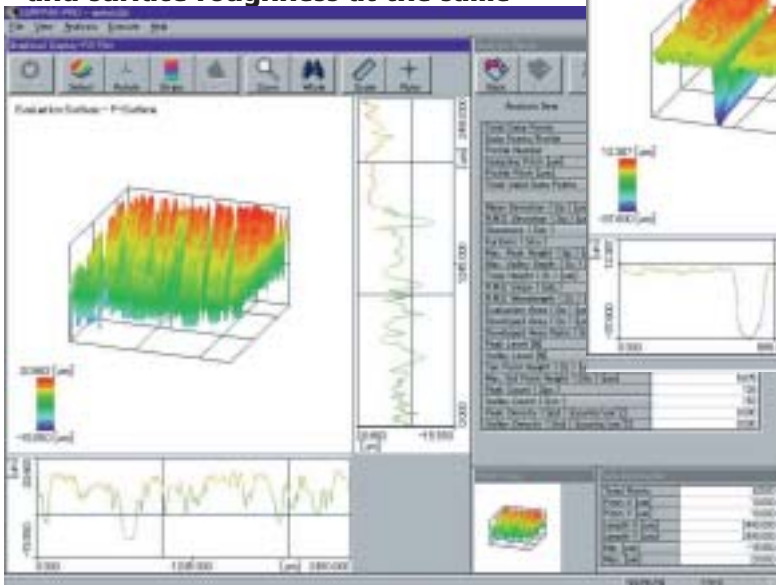

3-D topography (contour lines) display

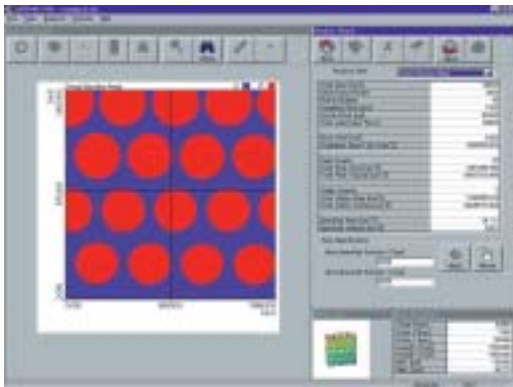

Cross-section analysis display

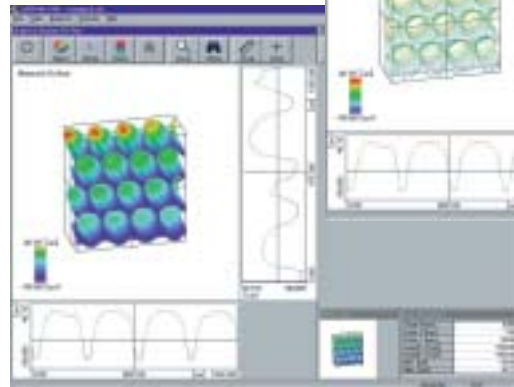

3-D topography display

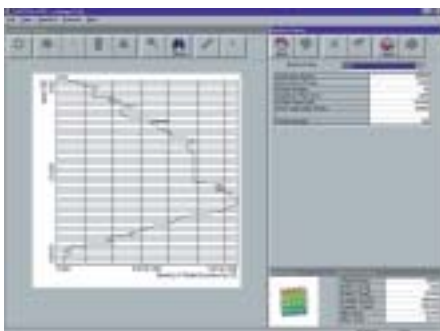

Peak-height distribution chart

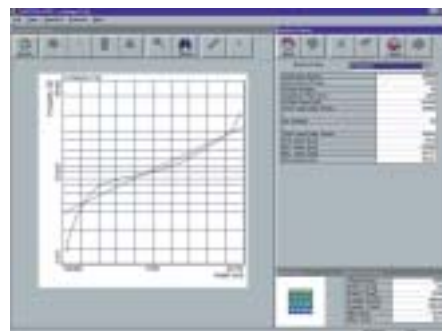

Probability distribution chart

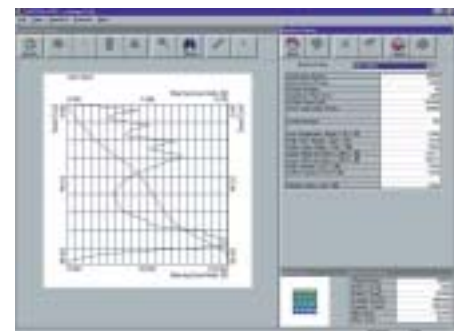

BAC (Bearing area curve) & ADC (Amplitude distribution chart)

SURFTEST SV-2000/3000 Series

Measurement Applications



Using a small hole stylus



Using a deep groove stylus

Detector

Order No.	Measuring force	Stylus
178-396-2	0.75mN	12AAC731 (standard type)
178-397-2	4mN	12AAB403 (standard type)

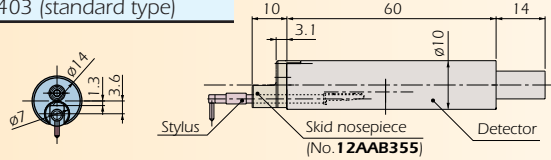

Unit: mm

Stylus

Standard type

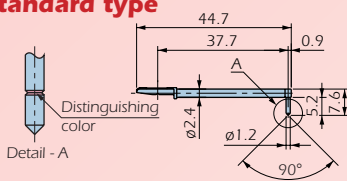

12AAC731 (2 μ m)*1
12AAB403 (5 μ m)
12AAB415 (10 μ m)
 (): Tip radius

Applicable skid nosepiece

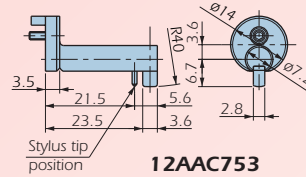

12AAC753

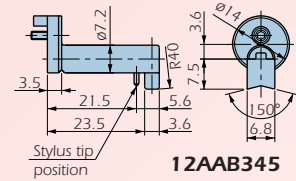

12AAB345

Small hole type

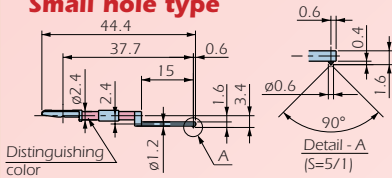

12AAC732 (2 μ m)*1
12AAB404 (5 μ m)
12AAB416 (10 μ m)
 (): Tip radius

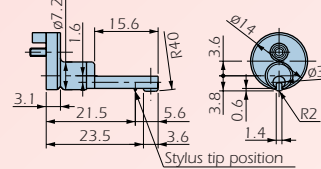

12AAC754

Extra small hole type

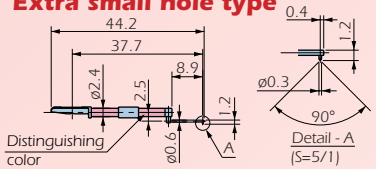

12AAC733 (2 μ m)*1
12AAB405 (5 μ m)
12AAB417 (10 μ m)
 (): Tip radius

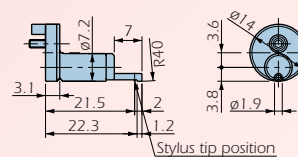

12AAB347

Extra small hole type

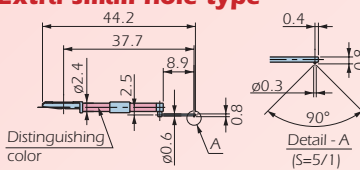

12AAC734 (2 μ m)*1
12AAB406 (5 μ m)
12AAB418 (10 μ m)
 (): Tip radius

Deep hole type

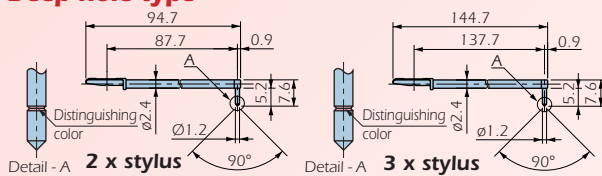

2 x stylus
12AAC740 (2 μ m)
12AAB413 (5 μ m)
12AAB425 (10 μ m)
 (): Tip radius

3 x stylus
12AAC741 (2 μ m)*1
12AAB414 (5 μ m)
12AAB426 (10 μ m)
 (): Tip radius

*1 Tip angle is 60°

Skidless nosepiece with stylus stopper

Used for measuring a workpiece having grooves the depth of which exceeds the measuring range of the detector. The stylus stopper prevents the stylus from falling into the grooves.

12AAC867



Skidless nosepiece

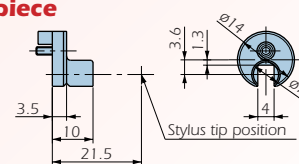

12AAB355

Stylus

Deep groove type*2

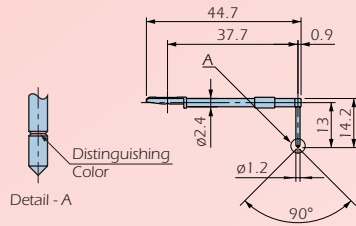

- 12AAC735** (2µm)*1
 - 12AAB409** (5µm)
 - 12AAB421** (10µm)
- () : Tip radius

Extra deep groove type*2

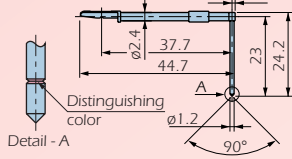

- 12AAC736** (2µm)*1
 - 12AAB408** (5µm)
 - 12AAB420** (10µm)
- () : Tip radius

Extra deep groove type*2

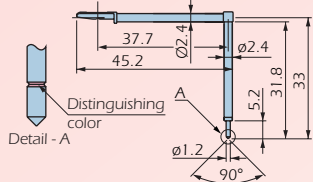

- 12AAC737** (2µm)*1
 - 12AAB407** (5µm)
 - 12AAB419** (10µm)
- () : Tip radius

Gear face type

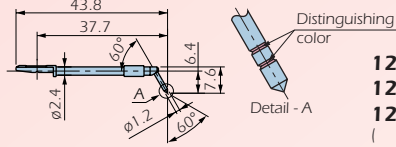

- 12AAB339** (2µm)*1
 - 12AAB410** (5µm)
 - 12AAB422** (10µm)
- () : Tip radius

WE-curve type

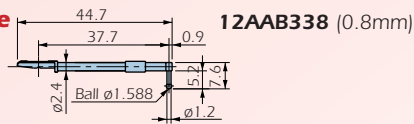

- 12AAB338** (0.8mm)

Knife edge type

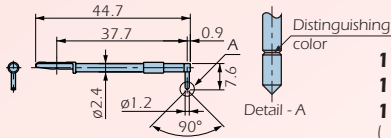

- 12AAC738** (2µm)*1
 - 12AAB411** (5µm)
 - 12AAB423** (10µm)
- () : Tip radius

Eccentric type*2

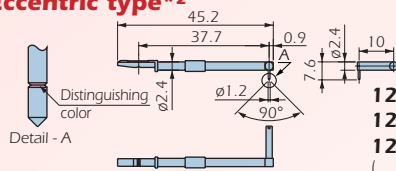

- 12AAC739** (2µm)*1
 - 12AAB412** (5µm)
 - 12AAB424** (10µm)
- () : Tip radius

Applicable skid nosepiece

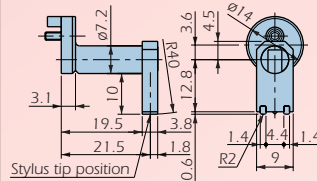

12AAB349

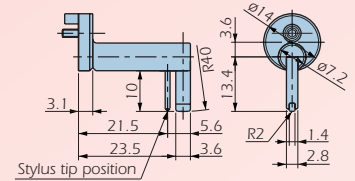

12AAC755

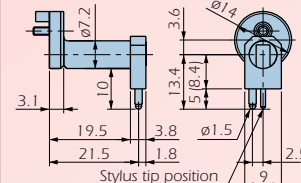

12AAB351

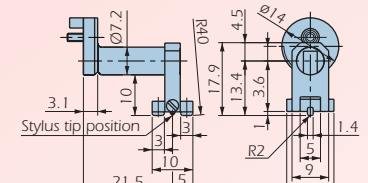

12AAB352

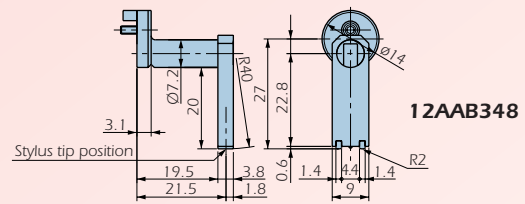

12AAB348

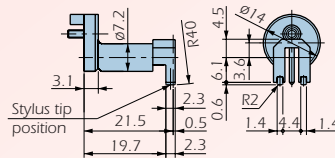

12AAB353

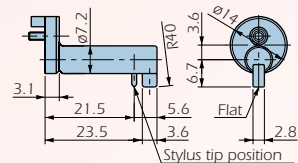

12AAC756

*1 Tip angle is 60° *2 The measuring force is not guaranteed when using this stylus.



Detector right angle adapter (SV-3000 series only)
 • Useable with standard stylus, gear face stylus, WE-curve stylus

OPTIONAL ACCESSORIES

Motor-driven accessories

Auto-leveling Table

- Leveling a workpiece for skidless measurement at high magnification requires skill and is time-consuming. Electrical correction for the inclination may involve errors depending on the method or the material of the workpiece, and on the radius of curvature of the stylus tip. The Auto-leveling Table solves these problems and allows exact workpiece leveling easily and quickly.

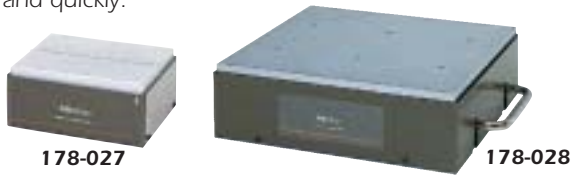

Order No.	178-027	178-028
Table top	130x100mm (5"x4")	280x250mm (11"x10")
Leveling range	±2°	
Max. table load	7kg (15.4 lbs.)	20kg (44 lbs.)
Dimensions (WxDxH)	135x105x57mm (5.31"x4.13"x2.24")	287x252x85mm (11.30"x9.92"x3.35")



Preliminary measurement



Measurement after auto-leveling

Traverse Table

- The Traverse Table is used for measuring workpieces whose dimensions exceed the traverse range of the Surftest Drive Unit. It moves the workpiece, and extends the tracing range up to 160mm (6.3").



178-044 (metric)
178-054 (inch/metric)

Order No.	178-044	178-054
Traverse range	160mm	6.3"
Table top	130x100mm	5"x4"
Leveling range	±1.5°	
Max. table load	10kg (22 lbs.)	
Linearity	0.5µm (19.6µin)	
Traverse speed	0.05mm/s, 0.5mm/s, 2mm/s (.002"/s, .02"/s, .08"/s) for measuring 0.5mm/s, 4mm/s (.02"/s, .16"/s) for positioning	
Dimensions (WxDxH)	535x185x117mm (21.16"x7.28"x4.61")	

Rolling Unit

- The Rolling Unit is used for measuring cylindrical and spherical workpieces that the Surftest SV-2000/3000 Series cannot otherwise measure. It rotates the workpiece mounted on it to measure the surface using the Surftest. Special nosepieces are used for measurement.



178-036

Nosepieces included

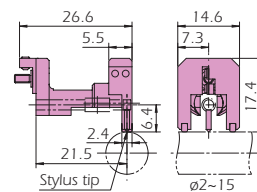

Cylinder (12AAC871)
Useable stylus: 12AAC731
(not included) 12AAB403
12AAB415

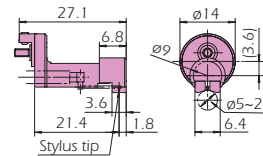

Sphere (12AAC872)
Useable stylus: 12AAC733
(not included) 12AAB405
12AAB417

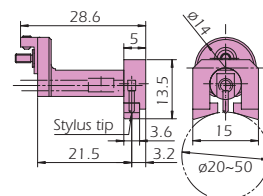

Sphere (12AAC873)
Useable stylus: 12AAC731
(not included) 12AAB403
12AAB415

Order No. 178-036	
Nosepieces	
Cylinder (12AAC871)	Diameter: 2 to 50mm (.08" to 1.97") Width: 20 to 100mm (.79" to 3.94")
Sphere (12AAC872)	Diameter: 5 to 20mm (.20" to .79")
Sphere (12AAC873)	Diameter: 20 to 50mm (.79" to 1.97")
Max. workpiece load	2kg (4.4 lbs.)
Measuring speed	0.1, 0.5, 1mm/s (.004", .02", .04"/s)
Rolling speed	0.05mm/s to 2mm/s (.002"/s to .08"/s)
Cutoff value	λc, fl = 8mm (.3") or less
Dimensions (WxDxH)	160x52x53mm (6.3"x2.1"x2.1")

Extension unit for SV-2000N2 and SV-3000M4

- The Extension Unit is required to connect up to two kinds of motor-driven options such as the Auto-leveling Table, Traverse Table or Rolling Unit with the Surftest SV-2000N2 and SV-3000M4.



998054
 □ Suffix: **A** for 120V, **D** for 220V, **E** for 240V or non for 100V

Add-on Unit for SV-2000N2/S2 and SV-3000M4

- The Add-on Unit is required to connect two or more kinds of motor-driven options, such as the Auto-leveling Table, Traverse Table or Rolling Unit with the Surftest SV-2000N2/S2 and SV-3000M4.

The Extension Unit (998054) is required for connecting to SV-2000N2/3000M4.



998055

3-axis Adjustment Table

This table helps make the alignment adjustments required when measuring cylindrical surfaces. The corrections for the pitch angle and the swivel angle are determined from a preliminary measurement and the Digimatic micrometers are adjusted accordingly. A flat-surfaced workpiece can also be leveled with this table.



178-047
3-axis Adjustment Table

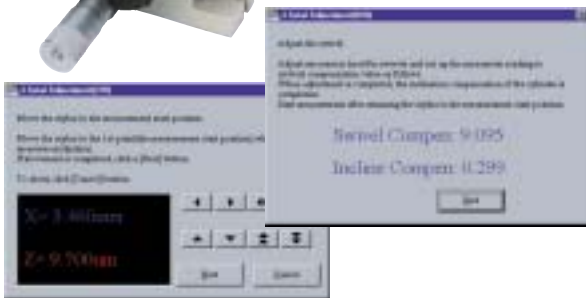

Order No.	178-047
Table top	130x100mm (5"x4")
Table loading	15kg (33 lbs.) maximum
Workpiece diameter	1mm to 160mm (.04" to 6.3")
Leveling range	±1.5°
Swivel range	±2°
Y-axis adjustment	±12.5mm (±.5")
Height	152.5mm (6")
Mass	9kg (19.8 lbs.)
Remarks	V-block (998291) is provided.

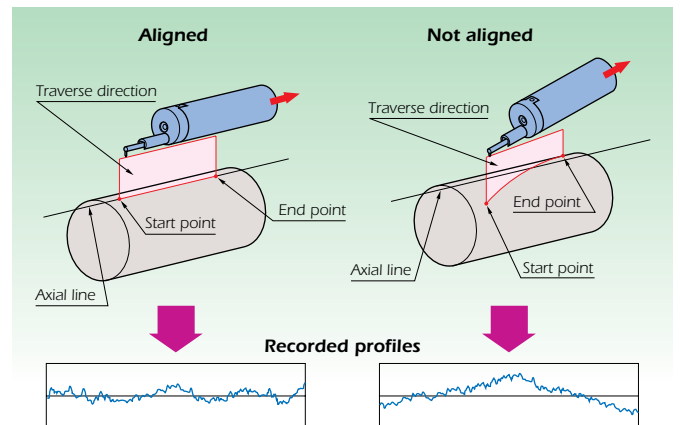

OPTIONAL ACCESSORIES

Step gage

Metric 4-step gage

- Step: 1µm, 2µm, 5µm, 10µm



178-610

Step gage

- Steps: 2µm (79µinch), 10µm (394µinch)



178-611 (mm)
178-612 (inch/mm)
for SV-2000N2/52000S2/3000M4

Vise

Precision vise

- Max. workpiece size: 36mm (1.42")
- Can be mounted on a leveling table.



178-019

Leveling tables

Leveling table

- Table top: 130x100mm (5"x4")
- Leveling range: ±1.5°
- Height: 40mm (1.57")

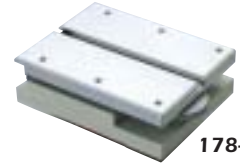

178-016

Workbenches

Adjustable workbench

- Dimensions (WxDxH): 1000x500x660mm (40"x20"x26")



218-007

Auxiliary desk

- Dimensions (WxDxH): 400x500x660mm (16"x20"x26")



218-008

Adjustable workbench

- Dimensions (WxDxH): 1200x750x670mm (48"x30"x27")



166-215

Auxiliary desk

- Dimensions (WxDxH): 550x500x700mm (22"x20"x28")



218-010

V-block

V-block

- Workpiece diameter: 1mm to 160mm (.04" to 6.3")
- Can be mounted on a leveling table.

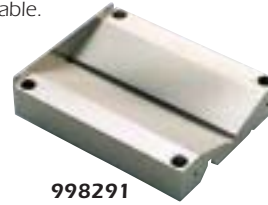

998291

XY leveling table with swivel

- Table top: 130x100mm (5"x4")
- Leveling range: ±1.5°
- XY travel: ±12.5mm (.5")
- Height: 83mm (3.27")

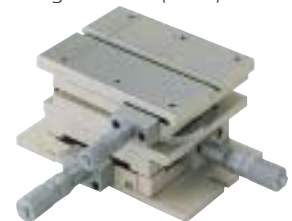

178-043-1 (metric)
178-053-1 (inch)

V-block with clamp

- Maximum workpiece diameter: 25mm (1")
- 2 blocks in a set.



181-902 (metric)
181-901 (inch)

Digimatic XY leveling table with swivel

- Table top: 130x100mm (5"x4")
- Leveling range: ±1.5°
- XY travel: ±12.5mm (.5")
- Height: 83mm (3.27")

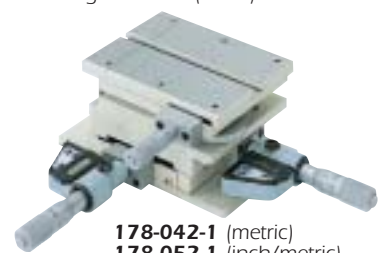

178-042-1 (metric)
178-052-1 (inch/metric)

Accessories for SV-2000N2

Cylinder attachment

- Diameter: 50 to 625mm (2" to 25")



997843

Column stand

- Dimensions (WxDxH): 600x350x730mm (24"x14"x29")
- Vertical travel: 330mm (13")



178-006

Column stand

- Dimensions (WxDxH): 370x200x540mm (15"x8"x21")
- Vertical travel: 200mm (7.8")



178-008

Vibration isolator

- Dimensions (WxDxH): 750x550x59mm (40"x20"x2.3")
- Stand is optional (178-024).



178-023



Optional software

Fine contour analyzing software **FORMPAK®-SV**

- **Evaluates contours on the workpiece surface that cannot be measured by surface roughness parameters.**
- **Performs various analyses/evaluations including contour evaluation of step, pitch and area calculations.**

The screenshot shows the main software window with a contour profile plot. The plot has several peaks labeled 'PeakPoint_1' through 'PeakPoint_4' and an 'Area_1' measurement. Below the plot is an 'Operation guide window' with instructions. At the bottom, there is an 'Operation procedure window' with a list of commands and their parameters. On the right side, there is a 'Command icons' panel and a 'Measurement result window' displaying numerical data.

Various Contour Evaluation Commands

- By combining contour elements such as point, line, circle, and coordinates, various evaluations can be performed, including the length measurement of step and pitch, the area calculation, etc.

Data Processing Function

- Allows assessed profile filtration, deletion of data, data cut-off, and combination of data from multiple measurements.

Data Compensation Function

- **Circular error compensation function:** Compensates circular movement error of the stylus to reduce distortion, thus obtaining the most accurate contour data possible.
- **Stylus-tip diameter compensation:** Offsets the measured data for the stylus-tip diameter.

Report Generation Function

- Just like the SURFPAK® Series software, FORMPAK®-SV allows measurement results to be freely laid out and printed out as report. This program also supports the optional color printer.

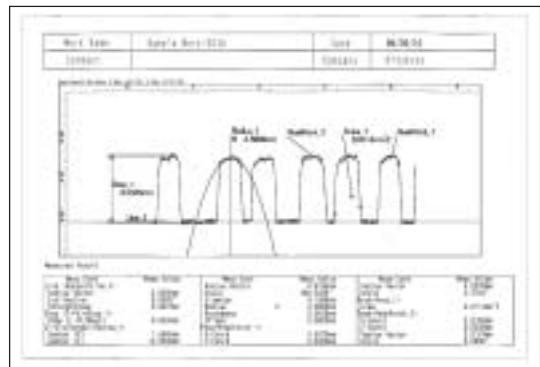

Surftest SV-2000/3000 Series data analysis capabilities

SURFPAK®-SV

International standards supported	ISO 4287: 1997, ANSI/ASME B46.1-1995, to be JIS B0601 1994
Assessed profiles	P (primary profile), R (roughness profile), WC, WCA, WE, WEA, DIN4776 profile, E (envelope residual profile), R-motif (roughness motif), W-motif (waviness motif)
Evaluation parameters	P, R, WC, WCA, WE, WEA, DIN 4776, E R-motif W-motif
Analysis graphs	Ra, Rq, Rz, Rz (JIS), Ry, Ry (DIN), Rc, Rp, Rpmax, Rpi, Rv, Rvmax, Rvi, Rt, Rti, R3z, R3zi, R3y, S, Pc (Ppi), Sm, HSC, mr, δc, plateau ratio, mrd, Rk, Rpk, Rvk, Mr1, Mr2, Δa, Δq, λa, λq, Sk, Ku, Lo, Lr, A1, A2 Rx, R, AR, SR, SAR, NR, NCRX, CPM Wte, Wx, W, AW, SW, SAW, NW
Digital filter	ADC, BAC1, BAC2, power spectrum chart, auto-correlation chart, Walsh power spectrum chart, Walsh auto-correlation chart, slope distribution chart, local peak distribution chart, parameter distribution chart
Cutoff length*	2CR-75%, 2CR-50%, 2CR-75% (phase corrected), 2CR-50% (phase corrected), Gaussian-50% (phase corrected)
Sampling length (L)*	λc: 0.025mm, 0.08mm, 0.25mm, 0.8mm, 2.5mm, 8mm, 25mm or arbitrary value (.001", .003", .01", .03", .1", .3", 1" or arbitrary value) fi: 0.08mm, 0.25mm, 0.8mm, 2.5mm, 8mm, 25mm or arbitrary value (.003", .01", .03", .1", .3", 1" or arbitrary value) fh: 0.08mm, 0.25mm, 0.8mm, 2.5mm, 8mm or arbitrary value (.003", .01", .03", .1", .3" or arbitrary value)
Data compensation	Tilt compensation, R-plane (curved surface) compensation, ellipse compensation, parabola compensation, hyperbola compensation, quadric curve automatic compensation, polynomial compensation, polynomial automatic compensation
Data deletion function	<ul style="list-style-type: none"> ▪ Data deletion to avoid an over-range error ▪ Data deletion in a specific range to perform recalculation ▪ Automatic data deletion (according to conditions set previously)
Recording magnifications	Vertical magnification: 100X - 500,000X Horizontal magnification: 1X - 10,000X
Special functions for report generation	<ul style="list-style-type: none"> ▪ Bit-map image paste-up function ▪ Multiple data layout function
OS requirement	Windows®95/Windows®98/Windows®NT4.0

* Arbitrary value can be specified in the range from 0.025mm (.001") to the maximum traverse length.

SURFPAK®-PRO (3-D Data Analysis Program for SV-3000-3D)

Three-dimensional evaluation parameters	Sa, Sq, Ssk, Sku, SΔq, Sλ, Sz, So, Sr, Sp, Sv, St, S3y, Spc, Svc, Spd, Svd, etc.
Three-dimensional filter function	Moving average filter, Gaussian filter
Three-dimensional trend compensation functions	Plane compensation, sphere compensation, cylinder compensation, polyhedron compensation
Three-dimensional analysis functions	3-D topography display, topographic profile analysis, BAC, ADC, power spectrum chart, probability distribution chart, local peak distribution chart, parameter distribution chart, slope enhancement
Topographic profile sampling function	A desired cross-section which is included in a three-dimensional topography data can be analyzed two-dimensionally.
Two-dimensional data analysis capabilities	Include the same evaluation parameters, analysis graphs, and functions as SURFPAK®-SV

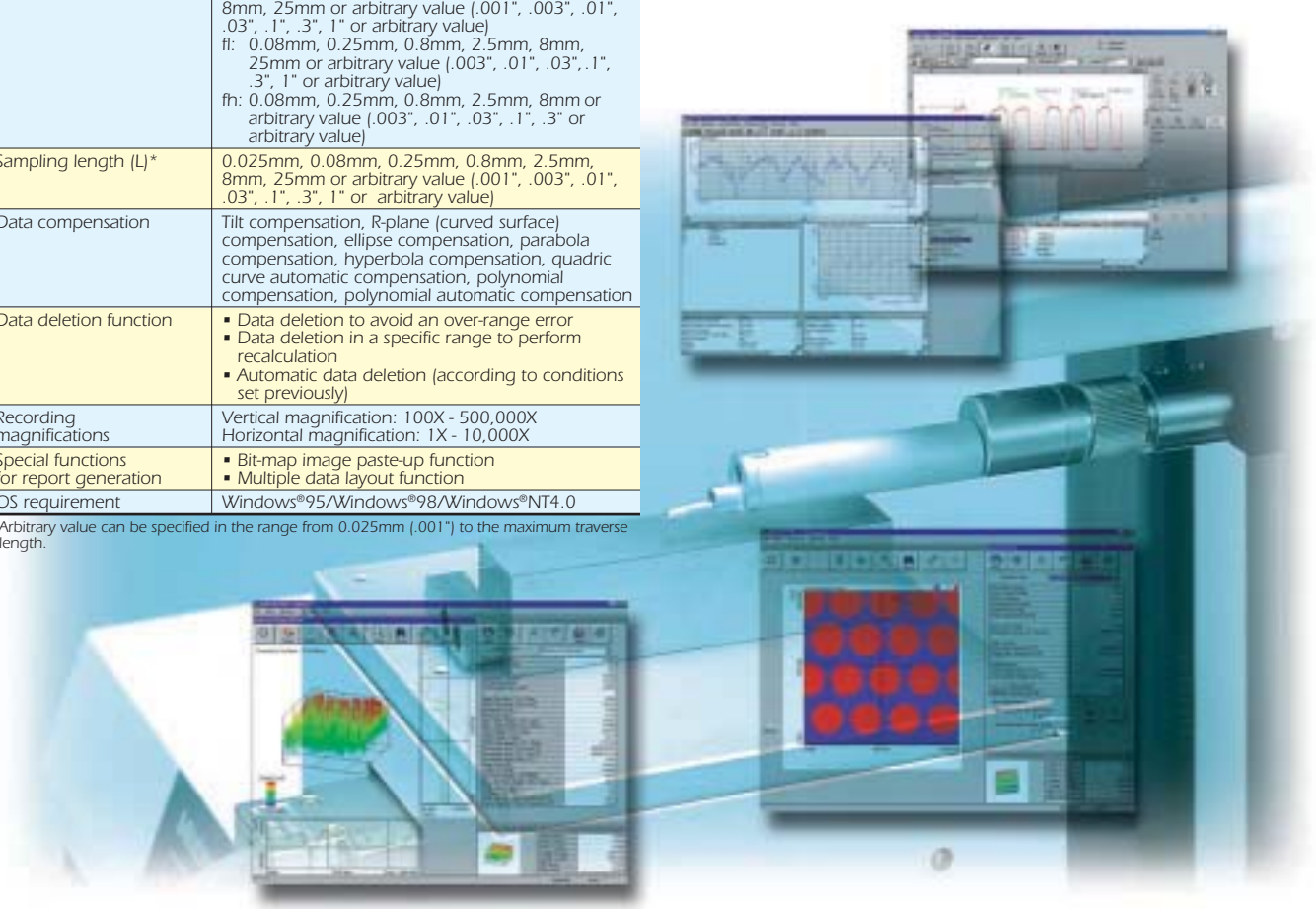

Dimensions

Unit: mm (inch)

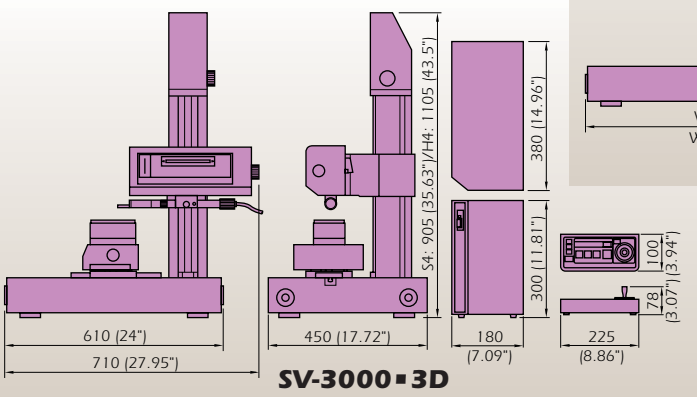
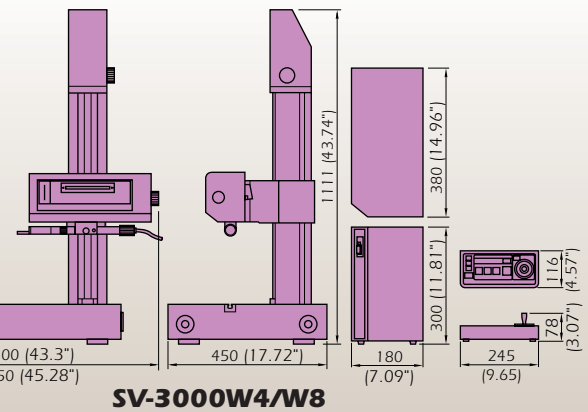
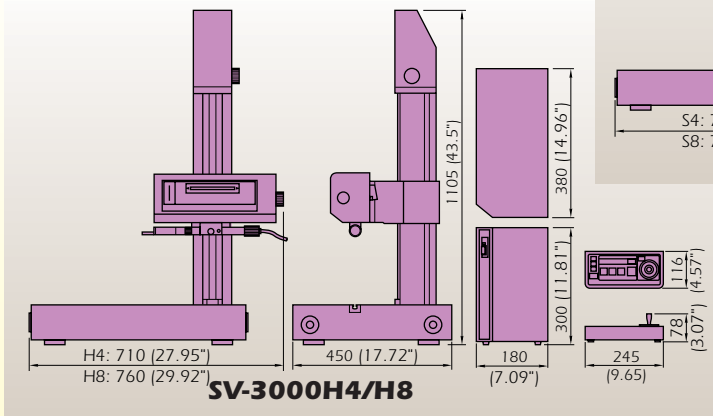
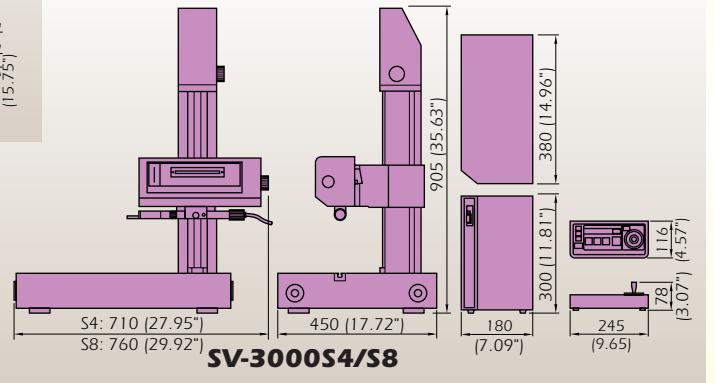
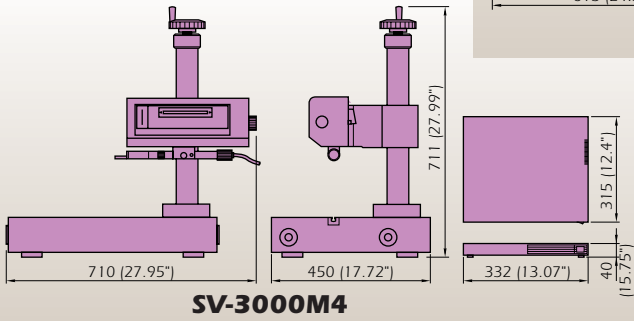
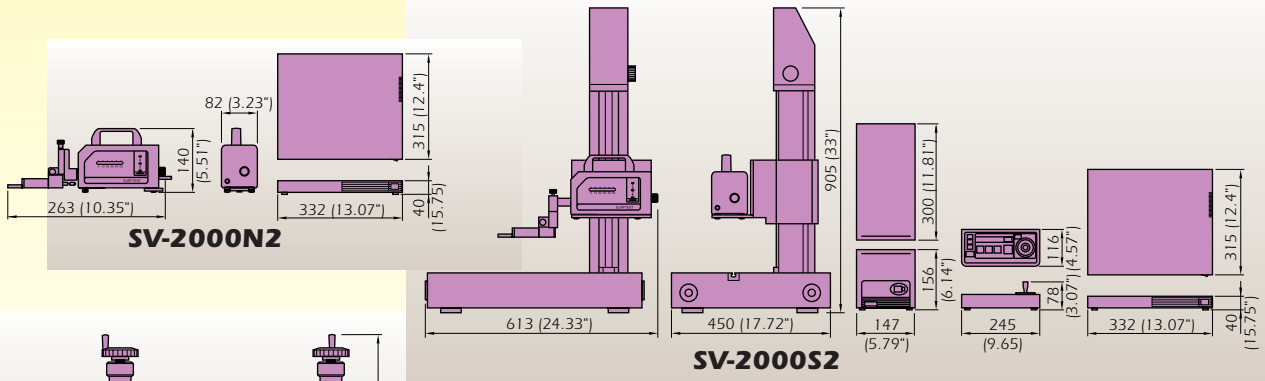

Note: An adjustable connector (**998047**) is required when using the Drive Unit separated from the power column.

Surface Roughness Testing System

Surftest SV-2000/3000

Specifications

Model No.	SV-2000N2		SV-2000S2		SV-3000M4		SV-3000S4		SV-3000H4		
Type	mm	inch/mm	mm	inch/mm	mm	inch/mm	mm	inch/mm	mm	inch/mm	
Order No.	100V AC	178-660	—	178-661	—	178-662	—	178-663	178-673	178-664	178-674
(Each order number suffix denotes the AC power cable type equipped.)	110V AC	178-660C	—	178-661C	—	178-662C	—	178-663C	—	178-664C	—
Measuring force of detector: 0.75mN	120V AC	178-660A	178-670A	178-661A	178-671A	178-662A	178-672A	178-663A	178-673A	178-664A	178-674A
	220V AC	178-660D	178-670D	178-661D	178-671D	178-662D	178-672D	178-663D	178-673D	178-664D	178-674D
	240V AC	178-660E	178-670E	178-661E	178-671E	178-662E	178-672E	178-663E	178-673E	178-664E	178-674E
Order No.	100V AC	178-640	—	178-641	—	178-642	—	178-643	178-653	178-644	178-654
(Each order number suffix denotes the AC power cable type equipped.)	110V AC	178-640C	—	178-641C	—	178-642C	—	178-643C	—	178-644C	—
Measuring force of detector: 4mN	120V AC	178-640A	178-650A	178-641A	178-651A	178-642A	178-652A	178-643A	178-653A	178-644A	178-654A
	220V AC	178-640D	178-650D	178-641D	178-651D	178-642D	178-652D	178-643D	178-653D	178-644D	178-654D
	240V AC	178-640E	178-650E	178-641E	178-651E	178-642E	178-652E	178-643E	178-653E	178-644E	178-654E
Traverse range	50mm (2")					100mm (4")					
Linearity of traverse	0.3µm/50mm (12µinch/2")					0.3µm/100mm (12µinch/4")		0.05+1.5L/1000µm ((2+1.5L)µinch) L=Measuring length			
Vertical travel	—		300mm (11.8") Power column (or manual)			300mm (11.8") Manual column		300mm (11.8") Power column		500mm (19.7") Power column	
Base Size (WxD)	—		610x450mm (24"x17.7")			610x450mm (24"x17.7")		610x450mm (24"x17.7")			
Stylus speed	Measuring	0.1mm/s (.004"/s), 0.2mm/s (.008"/s), 0.5mm/s (.02"/s), 1mm/s (.04"/s), 2mm/s (.08"/s)		0.02mm/s (.0008"/s), 0.05mm/s (.002"/s), 0.1mm/s (.004"/s), 0.2mm/s (.008"/s), 0.5mm/s (.02"/s), 1mm/s (.04"/s), 2mm/s (.08"/s)		0.05mm/s (.002"/s), 0.1mm/s (.004"/s), 0.2mm/s (.008"/s), 0.5mm/s (.02"/s), 1mm/s (.04"/s), 2mm/s (.08"/s)					
	Positioning	0.5mm/s (.02"/s), 2mm/s (.08"/s), Manual feed available		Can be adjusted with joystick 0.1mm/s to 5mm/s (.004"/s to .2"/s), Manual feed available		0.5mm/s (.02"/s), 2mm/s (.08"/s), Manual feed available					
Measuring range											
Standard detector	Detecting method										
	(178-396-2) (178-397-2)	Stylus									
	Skid										
Data analysis software	SURFPAK®SV (CD-ROM provided)										
Operating temperature											
Power supply											
Dimensions (WxDxH) of main unit	263x82x140mm (10.35"x3.2"x5.5")		618x450x905mm (24.33"x17.72"x33")			760x450x711mm (29.92"x17.72"x27.99")		710x450x905mm (27.95"x17.72"x36.63")		710x450x1105mm (27.95"x17.72"x43.5")	
Mass of main unit	2.8kg (6.16 lbs.)		130kg (286 lbs.)			140kg (308 lbs.)		140kg (308 lbs.)		150kg (330 lbs.)	
Standard accessories	Standard detector (178-396-2 (Measuring force: 0.75mN), 178-397-2 (Measuring force: 4mN)), standard nosepiece (12AAC753), roughness specimen (178-601 (mm) or 178-602 (inch/mm)), machine cover (355130)*, carrying bolts**, lubricant**, key wrenches, screwdriver, AC adapter, power cord, User's manual										
* Not included with SV-2000N2											
** Not included with SV-2000N2 or SV-3000M4											



SV-3000W4		SV-3000S8		SV-3000H8		SV-3000W8		SV-3000S4•3D		SV-3000H4•3D	
mm	inch/mm	mm	inch/mm	mm	inch/mm	mm	inch/mm	mm	inch/mm	mm	inch/mm
178-665	178-675	178-666	178-676	178-667	178-677	178-668	178-678	178-721	178-731	178-723	178-733
178-665C	—	178-666C	—	178-667C	—	178-668C	—	178-721C	—	178-723C	—
178-665A	178-675A	178-666A	178-676A	178-667A	178-677A	178-668A	178-678A	178-721A	178-731A	178-723A	178-733A
178-665D	178-675D	178-666D	178-676D	178-667D	178-677D	178-668D	178-678D	178-721D	178-731D	178-723D	178-733D
178-665E	178-675E	178-666E	178-676E	178-667E	178-677E	178-668E	178-678E	178-721E	178-731E	178-723E	178-733E
178-645	178-655	178-646	178-656	178-647	178-657	178-648	178-658	178-722	178-732	178-724	178-734
178-645C	—	178-646C	—	178-647C	—	178-648C	—	178-722C	—	178-724C	—
178-645A	178-655A	178-646A	178-656A	178-647A	178-657A	178-648A	178-658A	178-722A	178-732A	178-724A	178-734A
178-645D	178-655D	178-646D	178-656D	178-647D	178-657D	178-648D	178-658D	178-722D	178-732D	178-724D	178-734D
178-645E	178-655E	178-646E	178-656E	178-647E	178-657E	178-648E	178-658E	178-722E	178-732E	178-724E	178-734E
200mm (8")						100mm (4")					
0.5µm/200mm (20µinch/8")						0.05+1.5L/1000µm [(2+1.5L)µinch] <small>L=Measuring length</small>					
300mm (11.8") Power column			500mm (19.7") Power column			125mm (4.9") Power column					
1010x450mm (39.8"x17.7")		610x450mm (24"x17.7")			1010x450mm (39.8"x17.7")		610x450mm (24"x17.7")				
0.02mm/s (.0008"/s), 0.05mm/s (.002"/s), 0.1mm/s (.004"/s), 0.2mm/s (.008"/s), 0.5mm/s (.02"/s), 1mm/s (.04"/s), 2mm/s (.08"/s)											
Can be adjusted with joystick 0.1mm/s to 5mm/s (.004"/s to .2"/s), Manual feed available											
800µm [Resolution: 0.01µm] (32000µinch [Resolution: .4µinch]) 80µm [Resolution: 0.001µm] (3200µinch [Resolution: .04µinch]) 8µm [Resolution: 0.0001µm] (320µinch [Resolution: .004µinch])											
Differential inductance method											
Measuring force 0.75mN: Diamond, 60° cone, Tip radius: 2µm (79µinch) Measuring force 4mN: Diamond, 90° cone, Tip radius: 5µm (200µinch)											
Carbide, Radius of curvature: 40mm (1.6")											
						SURFPAK®-PRO (CD-ROM provided)					
15°C to 25°C											
100V AC - 240V AC, 50/60Hz											
1100x450x1111mm (43.3"x17.72"x43.74")		760x450x905mm (29.92"x17.72"x35.63")		760x450x1105mm (29.92"x17.72"x43.5")		1150x450x1111mm (45.28"x17.72"x43.74")		710x450x905mm (27.95"x17.72"x35.6")		710x450x1105mm (27.95"x17.72"x43.5")	
155kg (341 lbs.)		145kg (319 lbs.)		155kg (341 lbs.)		160kg (352 lbs.)		140kg (308 lbs.)		150kg (330 lbs.)	
Standard detector (178-396-2 (Measuring force: 0.75mN), 178-397-2 (Measuring force: 4mN)), standard nosepiece (12AAC753), roughness specimen (178-601 (mm) or 178-602 (inch/mm)), machine cover (355130 for SV-3000S4/S8) or 355270 for SV-3000H4/W4/H8/W8), key wrenches, screwdrivers, carrying bolts, lubricant, power cord, User's manual											

SURFTEST EXTREME SV-3000 CNC

CNC Form Measuring System evolves form measurement.



Coordinate Measuring Machines

Vision Measuring Systems

Surface-, Form- and Contour Measurement

Digital Scale and DRO Systems

Optical Measuring

Sensor Systems

Hardness Measuring

Small Tool Instruments and Data Management

Mitutoyo America Corporation
www.mitutoyo.com

M³ Solution Center

Michigan

Phone: (734) 459-2810

Massachusetts

Phone: (978) 692-8765

Illinois

Phone: (630) 978-5385

Indiana

Phone: (317) 577-6070

California

Phone: (626) 961-9661

North Carolina

Phone: (704) 875-8332

Job No. 11B-9

Note: All information regarding our products, and in particular the illustrations, drawings, dimensional and performance data contained in this pamphlet, as well as other technical data are to be regarded as approximate average values. We therefore reserve the right to make changes to the corresponding designs, dimensions and weights. The stated standards, similar technical regulations, descriptions and illustrations of the products were valid at the time of printing. In addition, the latest applicable version of our General Trading Conditions will apply. Only quotations submitted by ourselves may be regarded as definitive.

Mitutoyo